

HPXA15 and HPXB15 SERIES UNITS

The HPXA15 and HPXB15 are high efficiency residential split-system heat pump units, which features a scroll compressor and R410A refrigerant. Models are available in sizes ranging from 2 through 5 tons. The series is designed for use with an expansion valve only (approved for use with R410A) in the indoor unit. This manual is divided into sections which discuss the major components, refrigerant system, charging procedure, maintenance and operation sequence.

Information contained in this manual is intended for use by qualified service technicians only. All specifications are subject to change.



HPXB15 SHOWN

⚠ IMPORTANT
Operating pressures of this R410A unit are higher than pressures in R22 units. Always use service equipment rated for R410A.

⚠ WARNING
Refrigerant can be harmful if inhaled. Refrigerant must be used and recovered responsibly. Failure to follow this warning can lead to injury or death.

⚠ WARNING
Improper installation, adjustment, alteration, service or maintenance can cause property damage, personal injury or loss of life. Installation and service must be performed by a qualified installer or service agency.

⚠ WARNING

 Electric shock hazard. Can cause injury or death. Before attempting to perform any service or maintenance, turn the electrical power to unit OFF at disconnect switch(es). Unit may have multiple power supplies.

Table of Contents

General	1	III Refrigerant System	12
Specifications/Electrical Data HPXA15	2	IV Charging	14
Specifications/Electrical Data HPXB15	3	V Service and Recovery	19
I Application	4	VI Maintenance	19
II Unit Components	4	VII Diagrams and Operating Sequence	20

SPECIFICATIONS HPXA15

General Data		Model No.	HPXA15-024	HPXA15-030	HPXA15-036	HPXA15-042	HPXA15-048	HPXA15-060
Nominal Tonnage (kW)			2 (7.0)	2.5 (8.8)	3 (10.6)	3.5 (12.3)	4 (14.1)	5 (17.6)
Connections (sweat)	Liquid line o.d. - in. (mm)		3/8 (9.5)	3/8 (9.5)	3/8 (9.5)	3/8 (9.5)	3/8 (9.5)	3/8 (9.5)
	Vapor line o.d. - in. (mm)		3/4 (19)	3/4 (19)	3/4 (19)	7/8 (22.2)	7/8 (22.2)	1-1/8 (28.5)
**Refrigerant (R-410A) furnished			6 lbs. 15 oz. (3.14 kg)	10 lbs. 4 oz. (4.64 kg)	9 lbs. 10 oz. (4.36 kg)	9 lbs. 8 oz. (4.30 kg)	12 lbs. 7 oz. (5.63 kg)	14 lbs. 11 oz. (6.80 kg)
OutdoorCoil	Net face area sq. ft. (m ²) - Outer Coil		11.91 (1.11)	16.04 (1.49)	16.04 (1.49)	18.33 (1.70)	24.06 (2.24)	24.06 (2.24)
	Inner Coil		8.27 (0.77)	15.56 (1.45)	15.56 (1.45)	17.78 (1.65)	23.33 (2.17)	23.33 (2.17)
	Tube diameter - in. (mm)		5/16 (8)	5/16 (8)	5/16 (8)	5/16 (8)	5/16 (8)	5/16 (8)
	Number of rows		2	2	2	2	2	2
	Fins per inch (m)		22 (866)	22 (866)	22 (866)	22 (866)	22 (866)	22 (866)
Outdoor Fan	Diameter in. (mm) - No. of blades		20 (508) - 4	24 (610) - 3	24 (610) - 3	24 (610) - 3	24 (610) - 4	24 (610) - 4
	Motor hp (W)		1/10 (75)	1/6 (124)	1/6 (124)	1/6 (124)	1/4 (187)	1/4 (187)
	Cfm (L/s)		1860 (880)	3000 (1415)	3000 (1415)	3100 (1465)	4200 (1980)	4200 (1980)
	Rpm		825	825	825	825	825	825
	Watts		165	230	230	230	345	345
Shipping Data	1 package - lbs. (kg)		193 (88)	198 (90)	243 (110)	252 (114)	265 (120)	362 (164)
OPTIONAL ACCESSORIES - MUST BE ORDERED EXTRA								
Outdoor Thermostat Kit	Thermostat		56A87	56A87	56A87	56A87	56A87	56A87
	Mounting Box - US		31461	31461	31461	31461	31461	31461
	Canada		33A29	33A29	33A29	33A29	33A29	33A29
Plastic Mounting Base	Part No. - Catalog No.		69J06 (MB2-S)	69J07 (MB2-L)	69J07 (MB2-L)	69J07 (MB2-L)	69J07 (MB2-L)	69J07 (MB2-L)
	Net Weight		6 lbs. (3 kg)	15 lbs. (7 kg)	15 lbs. (7 kg)	15 lbs. (7 kg)	15 lbs. (7 kg)	15 lbs. (7 kg)
Refrigerant Line Set	15 ft. (4.6m) length		L15-41-15	L15-41-15	L15-41-15	L15-65-15	L15-65-15	Field Fabricate
	20 ft. (6 m) length		L15-41-20	L15-41-20	L15-41-20	L15-65-20	L15-65-20	Field Fabricate
	30 ft. (9 m) length		L15-41-30	L15-41-30	L15-41-30	L15-65-30	L15-65-30	Field Fabricate
	40 ft. (12 m) length		L15-41-40	L15-41-40	L15-41-40	L15-65-40	L15-65-40	Field Fabricate
	50 ft. (15 m) length		L15-41-50	L15-41-50	L15-41-50	L15-65-50	L15-65-50	Field Fabricate
	Suction/Vapor Line o.d. - in. (mm)		3/4 (19)	3/4 (19)	3/4 (19)	7/8 (22.2)	7/8 (22.2)	1-1/8 (22.2)
	Liquid Line o.d. - in. (mm)		3/8 (9.5)	3/8 (9.5)	3/8 (9.5)	3/8 (9.5)	3/8 (9.5)	3/8 (9.5)

*Refrigerant charge sufficient for 15 ft. (4.5 m) length of refrigerant lines.

ELECTRICAL DATA HPXA15

Model No.		HPXA15-024	HPXA15-030	HPXA15-036	HPXA15-042	HPXA15-048	HPXA15-060
Line voltage data - 60 hertz - 1 phase		208/230v					
Rec. max. fuse or circuit breaker size (amps)		30	30	35	40	45	60
*Minimum circuit ampacity		17.7	19.6	20.4	25.2	27.5	36.2
Compressor	Rated load amps	13.5	14.8	15.4	19.3	20.6	27.6
	Power factor	.98		.97	.95	.94	.99
	Locked rotor amps	61.0	72.5	83.0	104.0	109.0	158.0
Outdoor Coil Fan Motor	Full load amps	0.8	1.1			1.7	1.7
	Locked rotor amps	1.6	2.0			3.8	3.8

*Refer to National or Canadian Electrical Code manual to determine wire, fuse and disconnect size requirements.

NOTE — Extremes of operating range are plus 10% and minus 5% of line voltage.

HPXB15

SPECIFICATIONS

General Data	Model No.	HPXB15-024 -230	HPXB15-030 -230	HPXB15-036 -230	HPXB15-042 -230	HPXB15-048 -230	HPXB15-060 -230
	Nominal Tonnage (kW)	2 (7.0)	2.5 (8.8)	3 (10.6)	3.5 (12.3)	4 (14.1)	5 (17.6)
Connections (sweat)	Liquid line o.d. - in. (mm)	3/8 (9.5)	3/8 (9.5)	3/8 (9.5)	3/8 (9.5)	3/8 (9.5)	3/8 (9.5)
	Vapor line o.d. - in. (mm)	3/4 (19)	3/4 (19)	3/4 (19)	7/8 (22.2)	7/8 (22.2)	1-1/8 (28.5)
Refrigerant	☐ R-410A furnished	6 lbs. 15 oz. (3.15 kg)	10 lbs. 4 oz. (4.65 kg)	9 lbs. 10 oz. (4.37 kg)	9 lbs. 8 oz. (4.31 kg)	12 lbs. 7 oz. (5.64 kg)	14 lbs. 11 oz. (6.66 kg)
OutdoorCoil	Net face area sq. ft. (m ²) - Outer Coil	11.91 (1.11)	16.04 (1.49)	16.04 (1.49)	18.33 (1.70)	24.06 (2.24)	24.06 (2.24)
	Inner Coil	8.27 (0.77)	15.56 (1.45)	15.56 (1.45)	17.78 (1.65)	23.33 (2.17)	23.33 (2.17)
	Tube diameter - in. (mm)	5/16 (8)	5/16 (8)	5/16 (8)	5/16 (8)	5/16 (8)	5/16 (8)
	Number of rows	2	2	2	2	2	2
	Fins per inch (m)	22 (866)	22 (866)	22 (866)	22 (866)	22 (866)	22 (866)
Outdoor Fan	Diameter in. (mm) - No. of blades	20 (508) - 4	24 (610) - 3	24 (610) - 3	24 (610) - 3	24 (610) - 4	24 (610) - 4
	Motor hp (W)	1/10 (75)	1/6 (124)	1/6 (124)	1/6 (124)	1/4 (187)	1/4 (187)
	Cfm (L/s)	1860 (880)	3000 (1415)	3000 (1415)	3100 (1465)	4200 (1980)	4200 (1980)
	Rpm	825	825	825	825	825	825
	Watts	165	230	230	230	345	345
Shipping Data	lbs. (kg) 1 package	196 (89)	203 (92)	248 (112)	257 (116)	270 (122)	367 (166)

ELECTRICAL DATA

Electrical Data	Line voltage data - 60 hertz - 1 phase	208/230v	208/230v	208/230v	208/230v	208/230v	208/230v
	Maximum fuse size (amps)	30	30	35	40	45	60
	*Minimum circuit ampacity	17.7	19.6	20.4	25.2	27.5	36.2
Compressor	Rated load amps	13.5	14.8	15.4	19.3	20.6	27.6
	Locked rotor amps	61.0	72.5	83.0	104.0	109.0	158.0
	Power factor	.98	.98	.97	.95	.94	.99
Outdoor Coil Fan Motor	Full load amps	0.8	1.1	1.1	1.1	1.7	1.7
	Locked rotor amps	1.6	2.0	2.0	2.0	3.8	3.8

OPTIONAL ACCESSORIES - MUST BE ORDERED EXTRA

Compressor Hard Start Kit		10J42	10J42	10J42	10J42	81J69	81J69
Driers	Liquid Line - sweat connections	44L40	44L40	44L40	44L40	44L40	44L40
	Suction Line - sweat connections	88K44	88K44	88K44	88K45	88K45	88K45
Mounting Base	Part No. - Catalog No.	69J06 (MB2-S)	69J07 (MB2-L)	69J07 (MB2-L)	69J07 (MB2-L)	69J07 (MB2-L)	69J07 (MB2-L)
	Net Weight	6 lbs. (3 kg)	15 lbs. (7 kg)	15 lbs. (7 kg)	15 lbs. (7 kg)	15 lbs. (7 kg)	15 lbs. (7 kg)
Outdoor Thermostat Kit	Thermostat	56A87	56A87	56A87	56A87	56A87	56A87
	Mounting Box - US	31461	31461	31461	31461	31461	31461
	Canada	33A29	33A29	33A29	33A29	33A29	33A29
Refrigerant Line Set	15 ft. (4.6 m) length	L15-41-15	L15-41-15	L15-41-15	L15-65-15	L15-65-15	Field Fabricate
	20 ft. (6 m) length	L15-41-20	L15-41-20	L15-41-20	L15-65-20	L15-65-20	Field Fabricate
	30 ft. (9 m) length	L15-41-30	L15-41-30	L15-41-30	L15-65-30	L15-65-30	Field Fabricate
	40 ft. (12 m) length	L15-41-40	L15-41-40	L15-41-40	L15-65-40	L15-65-40	Field Fabricate
	50 ft. (15 m) length	L15-41-50	L15-41-50	L15-41-50	L15-65-50	L15-65-50	Field Fabricate

☐ Refrigerant charge sufficient for 15 ft. (4.6 m) length of refrigerant lines.

*Refer to National or Canadian Electrical Code manual to determine wire, fuse and disconnect size requirements.

NOTE — Extremes of operating range are plus 10% and minus 5% of line voltage.

I-APPLICATION

All major components (indoor blower and coil) must be matched according to Lennox recommendations for the compressor to be covered under warranty. Refer to the Engineering Handbook for approved system matchups. A misapplied system will cause erratic operation and can result in early compressor failure.

▲ IMPORTANT

This unit must be matched with an indoor coil as specified in Lennox® Engineering Handbook.

II-Unit Components

The contactor coil, defrost board, reversing valve (all units) and system operation monitor (HPXB15 only) are all energized by 24VAC supplied by the indoor unit. All other components in the outdoor unit are powered by line voltage. Refer to unit wiring diagram. The HPXA15 and HPXB15 units are not equipped with an internal line voltage to 24V transformer.

A-Compressor (B1)

The scroll compressors in all units are designed for use with R410A refrigerant and operation at high pressures. Compressors are shipped from the factory with 3MA (32MMMA) P.O.E. oil. See electrical section in this manual for compressor specifications.

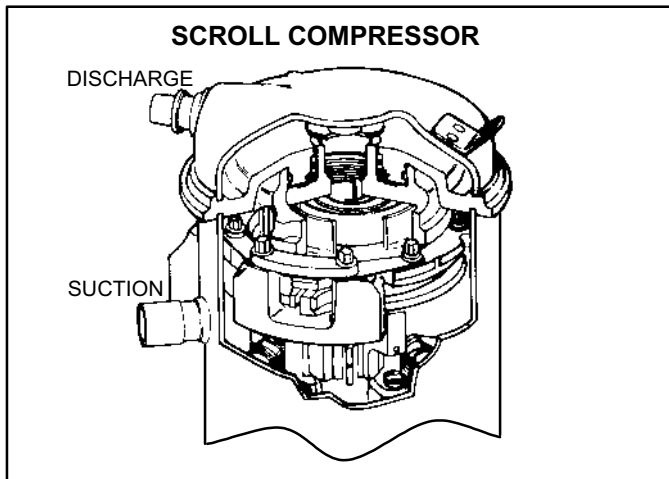

FIGURE 1

The scroll compressor design is simple, efficient and requires few moving parts. A cutaway diagram of the scroll compressor is shown in figure 1. The scrolls are located in the top of the compressor can and the motor is located just below. The oil level is immediately below the motor.

The scroll is a simple compression concept centered around the unique spiral shape of the scroll and its inherent properties. Figure 2 shows the basic scroll form. Two identical scrolls are mated together forming concentric spiral shapes (figure 3). One scroll remains stationary, while the other is allowed to "orbit" (figure 4). Note that the orbiting scroll does not rotate or turn but merely "orbits" the stationary scroll.

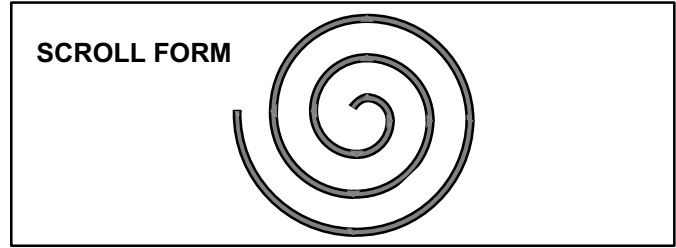

FIGURE 2

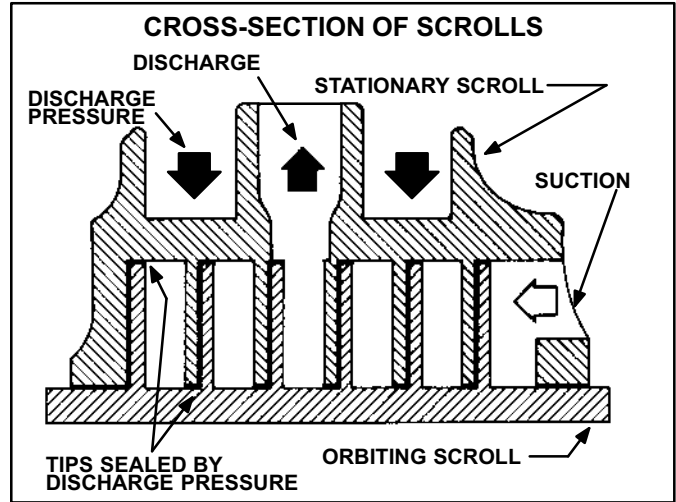

FIGURE 3

The counterclockwise orbiting scroll draws gas into the outer crescent shaped gas pocket created by the two scrolls (figure 4 - 1). The centrifugal action of the orbiting scroll seals off the flanks of the scrolls (figure 4 - 2). As the orbiting motion continues, the gas is forced toward the center of the scroll and the gas pocket becomes compressed (figure 4 -3). When the compressed gas reaches the center, it is discharged vertically into a chamber and discharge port in the top of the compressor (figure 1). The discharge pressure forcing down on the top scroll helps seal off the upper and lower edges (tips) of the scrolls (figure 3). During a single orbit, several pockets of gas are compressed simultaneously providing smooth continuous compression.

The scroll compressor is tolerant to the effects of liquid return. If liquid enters the scrolls, the orbiting scroll is allowed to separate from the stationary scroll. The liquid is worked toward the center of the scroll and is discharged. If the compressor is replaced, conventional Lennox cleanup practices must be used.

Due to its efficiency, the scroll compressor is capable of drawing a much deeper vacuum than reciprocating compressors. Deep vacuum operation can cause internal fuse arcing resulting in damaged internal parts and will result in compressor failure. Never use a scroll compressor for evacuating or "pumping-down" the system. This type of damage can be detected and will result in denial of warranty claims.

NOTE - During operation, the head of a scroll compressor may be hot since it is in constant contact with discharge gas.

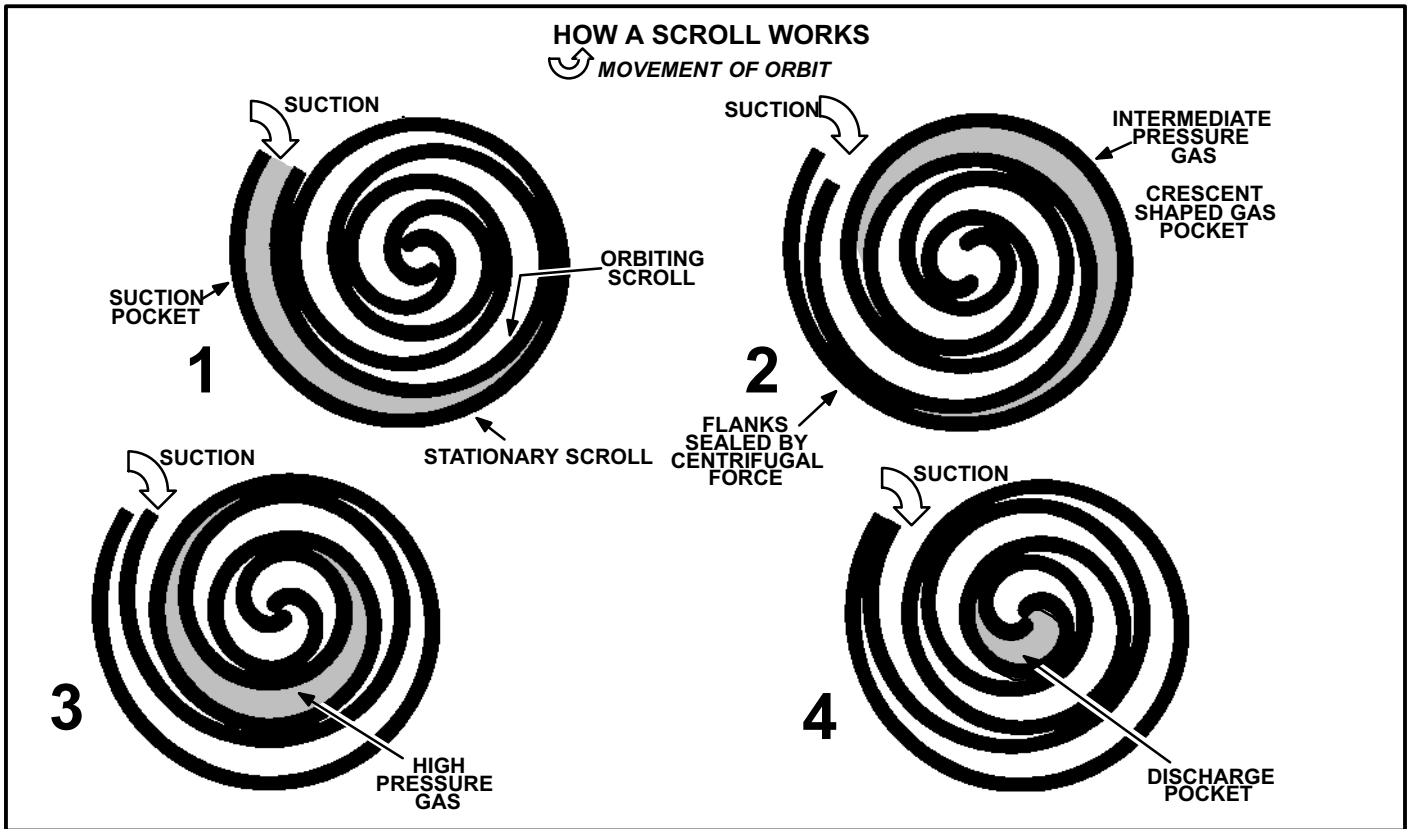

FIGURE 4

B-Contactor (K1)

The compressor is energized by a contactor located in the control box. All units are single phase and use single-pole contactors.

⚠ DANGER

Electric Shock Hazard.
May cause injury or death.

Line voltage is present at all components when unit is not in operation on units with single pole contactors.

Disconnect all remote electrical power supplies before opening unit panel.

Unit may have multiple power supplies.

ELECTROSTATIC DISCHARGE (ESD) Precautions and Procedures

⚠ CAUTION

Electrostatic discharge can affect electronic components. Take precautions during unit installation and service to protect the unit's electronic controls. Precautions will help to avoid control exposure to electrostatic discharge by putting the unit, the control and the technician at the same electrostatic potential. Neutralize electrostatic charge by touching hand and all tools on an unpainted unit surface before performing any service procedure.

C-Reversing Valve (L1)

A refrigerant reversing valve with an electromechanical solenoid is used to reverse refrigerant flow during unit operation. The reversing valve is energized during cooling demand and during defrost.

D-High Pressure Switch (S4)

⚠ IMPORTANT

Pressure switch settings for R410A refrigerant will be significantly higher than units with R22.

An auto-reset, single-pole/single-throw high pressure switch is located in the liquid line. This switch shuts off the compressor when liquid line pressure rises above the factory setting. The switch is normally closed and is permanently adjusted to trip (open) at 640 ± 10 psi and reset (close) at 448 ± 10 psi. See figure 5 for switch location.

E-Crankcase Heater (HR1)

Compressors in all 2 1/2 to 5 ton units are equipped with a 70 watt bellyband type crankcaseheater. HR1 prevents liquid from accumulating in the compressor. HR1 is controlled by the crankcaseheater thermostat.

F- Crankcaseheater Thermostat (S40)

Thermostat S40 controls the crankcaseheater in 2 1/2 to 5 ton units. S40 is located on the liquid line. When liquid line temperature drops below 50° F the thermostat S40 closes energizing HR1. The thermostat will open, de-energizing HR1 once liquid line temperature reaches 70° F.

G-Dual Capacitor (C12)

The compressor and fan in all units use permanent split capacitor motors. A single "dual" capacitor is used for both the fan motor and the compressor (see unit wiring diagram). The two sides (fan and compressor) of the capacitor have different mfd ratings and may change with each compressor. The capacitor is located inside the unit control box.

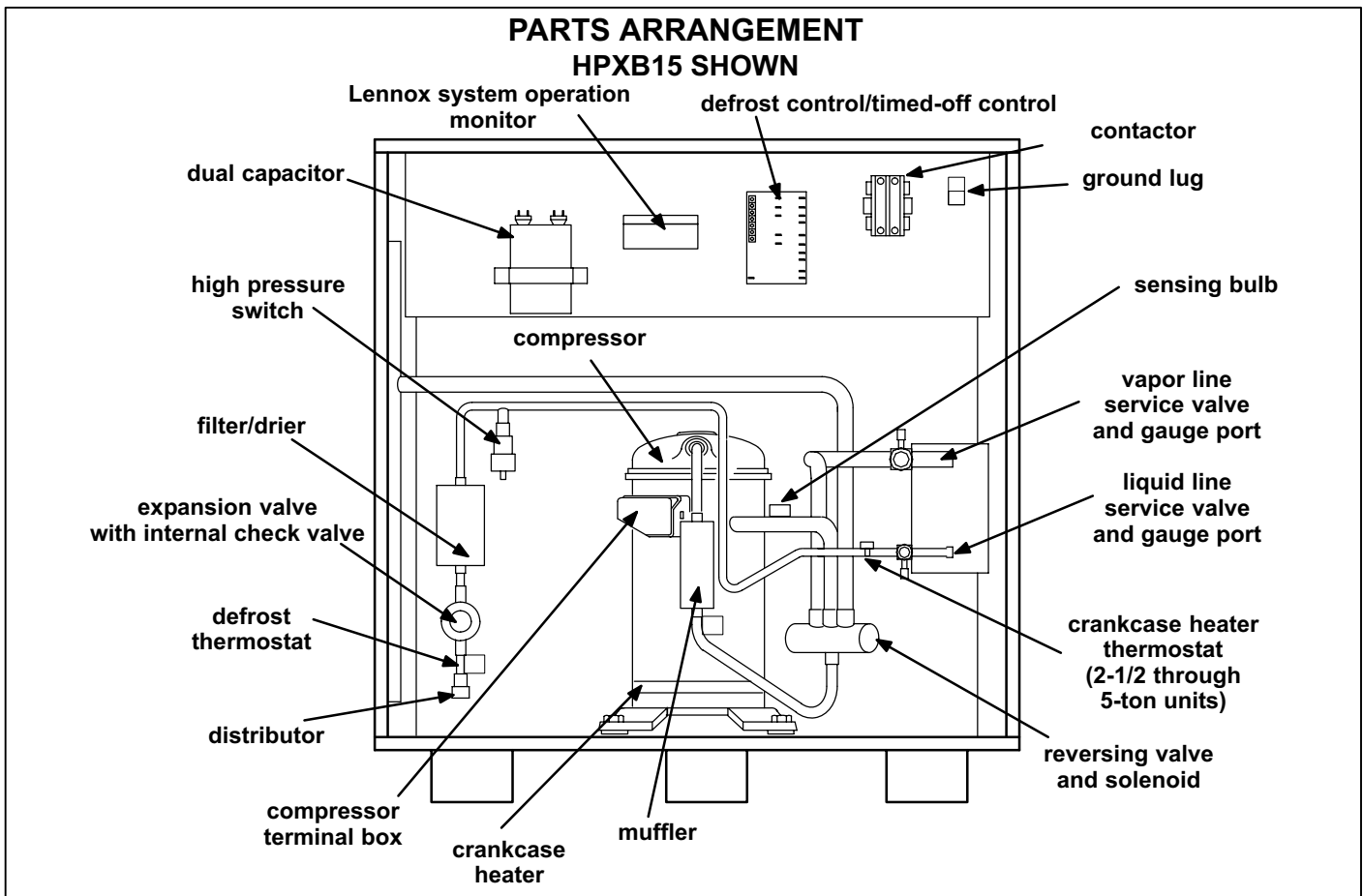

FIGURE 5

H-Condenser Fan Motor (B4)

All units use single-phase PSC fan motors which require a run capacitor. The "FAN" side of the dual capacitor is used for this purpose. In all units, the outdoor fan is controlled by the compressor contactor. See ELECTRICAL DATA and SPECIFICATIONS section for more information. See figure 6 if condenser fan motor replacement is necessary.

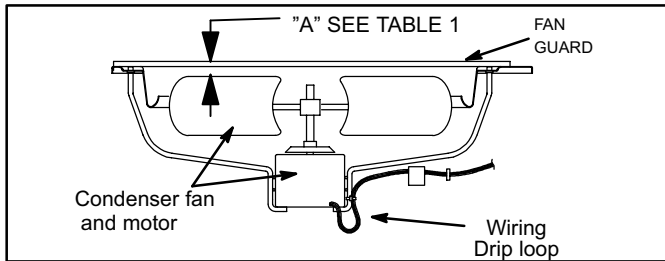

FIGURE 6

TABLE 1

UNIT	"A" DIM. $\pm 1/8$ "	Fan Blade
-24	7/8"	Lau
		Revcor
-30, -36, -42	1-1/16"	Lau
		Revcor
-48	1-3/4"	Lau
	1-1/2"	Revcor
-60	1-3/16"	Lau
		Revcor

I-Service Light Thermostat (S54)

HPXA15-1 and -2 units only are equipped with a service light thermostat located on the compressor discharge line. The switch is electrically connected to the service light in the indoor thermostat. The service light, when lit, indicates the compressor is not running. The service light thermostat will close and light when the discharge line falls below $110 \pm 5^\circ\text{F}$, indicating a problem in the system. The service light thermostat opens and the service light goes off when discharge line reaches $130 \pm 5^\circ\text{F}$ indicating the compressor is running. Service light connections are made on terminals on the defrost control board (figure 8).

J-Ambient Compensating Thermistor (RT3)

HPXA15-1 and -2 units only have an ambient compensating thermistor mounted on the outdoor fan wiring harness. The thermistor is an NTC thermistor (negative temperature coefficient - increase in temperature equals decrease in resistance) (see figure 7). The device is connected in series with the heat anticipation resistor inside the indoor thermostat. The thermistor varies the indoor thermostat heat anticipator current according to outdoor ambient temperature to prevent abnormal thermostat droop. As outdoor temperature increases, the resistance across the thermistor drops. As the resistance across the thermistor drops, the current through the heat anticipation resistor increases. Therefore, heat anticipation increases as outdoor temperature decreases. Resistance at $77^\circ\text{F} = 260 \text{ ohms} \pm 5\%$; at $100^\circ\text{F} = 150 \text{ ohms}$; at $32^\circ\text{F} = 861 \text{ ohms}$. Ambient thermistor connections are made at terminals on the defrost control.

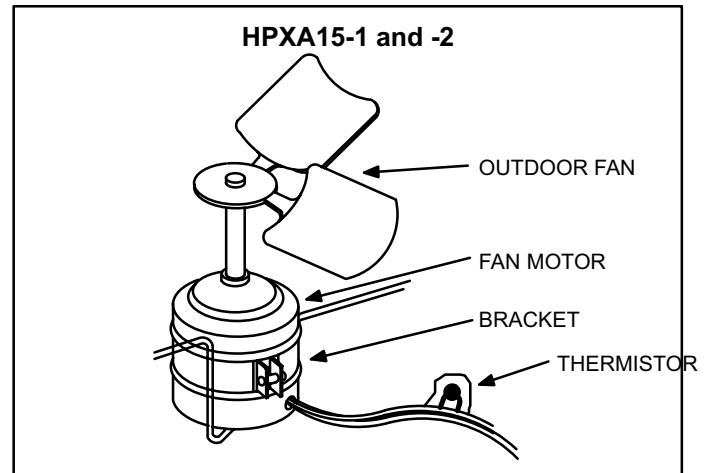

FIGURE 7

K-Lennox System Operation Monitor (A132)

HPXB15 units only are equipped with the Lennox system operation monitor. The system operation monitor is a 24 volt power module, wired directly to the indoor unit. The LSOM is located in the control box and is used to troubleshoot problems in the system. The module has three LED's for troubleshooting: GREEN indicates power status, YELLOW indicates an abnormal condition and RED indicates thermostat demand, but compressor not operating. See table 2 for troubleshooting codes.

⚠ IMPORTANT

The LSOM is not a safety component and cannot shut down or control the HPXB15. The LSOM is a monitoring device only.

TABLE 2

Status LED	Status LED Description	Status LED Troubleshooting Information
Green "Power"	Module has power.	Supply voltage is present at module terminals.
Red "Trip"	Thermostat demand signal Y1 is present, but the compressor is not running. NOTE - during 5 minute delay in defrost board the red "trip" light will be on.	<ol style="list-style-type: none"> 1 Compressor protector is open. 2 Outdoor unit power disconnect is open. 3 Compressor circuit breaker or fuse(s) is open. 4 Broken wire or connector is not making contact. 5 Low pressure switch open if present in the system. 6 Compressor contactor has failed to close.
Yellow "Alert" Flash Code 1 (Does not apply to heat pump or to two-stage split systems)	Long Run Time Compressor is running extremely long run cycles	<ol style="list-style-type: none"> 1 Low refrigerant charge. 2 Evaporator blower is not running. 3 Evaporator coil is frozen. 4 Faulty metering device. 5 Condenser coil is dirty 6 Liquid line restriction (filter drier blocked if present) 7 Thermostat is malfunctioning.
Yellow "Alert" Flash Code 2	System Pressure Trip Discharge or suction pressure out of limits or compressor overloaded	<ol style="list-style-type: none"> 1 High head pressure. 2 Condenser coil poor air circulation (dirty, blocked, damaged). 3 Condenser fan is not running. 4 Return air duct has substantial leakage. 5 If low pressure switch is present, check Flash Code 1 information.
Yellow "Alert" Flash Code 3	Short Cycling Compressor is running only briefly	<ol style="list-style-type: none"> 1 Thermostat demand signal is intermittent. 2 Time delay relay or control board is defective. 3 If high pressure switch is present, check Flash Code 2 information. 4 If low pressure switch is present, check Flash Code 1 information.
Yellow "Alert" Flash Code 4	Locked Rotor	<ol style="list-style-type: none"> 1 Run capacitor has failed. 2 Low line voltage (contact utility if voltage at disconnect is low). 3 Excessive liquid refrigerant in the compressor. 4 Compressor bearings are seized.
Yellow "Alert" Flash Code 5	Open Circuit	<ol style="list-style-type: none"> 1 Outdoor unit power disconnect is open. 2 Unit circuit breaker or fuse(s) is open. 3 Unit contactor has failed to close. 4 High pressure switch is open and requires manual reset. 5 Open circuit in compressor supply wiring or connections. 6 Unusually long compressor protector reset time due to extreme ambient temperature. 7 Compressor windings are damaged.
Yellow "Alert" Flash Code 6	Open Start Circuit Current only in run circuit	<ol style="list-style-type: none"> 1 Run capacitor has failed. 2 Open circuit in compressor start wiring or connections. 3 Compressor start winding is damaged.
Yellow "Alert" Flash Code 7	Open Run Circuit Current only in start circuit	<ol style="list-style-type: none"> 1 Open circuit in compressor start wiring or connections. 2 Compressor start winding is damaged.
Yellow "Alert" Flash Code 8	Welded Contactor Compressor always runs	<ol style="list-style-type: none"> 1 Compressor contactor failed to open. 2 Thermostat demand signal not connected to module.
Yellow "Alert" Flash Code 9	Low Voltage Control circuit < 17VAC	<ol style="list-style-type: none"> 1 Control circuit transformer is overloaded 2 Low line voltage (contact utility if voltage at disconnect is low).

•Flash code number corresponds to a number of LED flashes, followed by a pause, and then repeated.

•TRIP and ALERT LEDs flashing at the same time indicates that the control circuit voltage is too low for operation.

•Reset ALERT flash code by removing 24VAC power from monitor. Last ALERT flash code will display for 1 minute after monitor is powered on.

L-Time / Temperature Defrost System HPXA15-1 Units

The defrost system includes two components: a defrost thermostat, and a defrost control.

Defrost Thermostat

The defrost thermostat is mounted on the liquid line between the check/expansion valve and the distributor. When defrost thermostat senses 35°F (2°C) or cooler, its contacts close and send a signal to the defrost control board to start the defrost timing. It also terminates defrost when the liquid line warms up to 70°F (21°C).

Defrost Control

The defrost control board combines functions of a time/temperature defrost control, defrost relay, time delay, diagnostic LEDs and field connection terminal strip. See figure 8.

The control provides automatic switching from normal heating operation to defrost mode and back. During compressor cycle (room thermostat demand cycle), if the “O” input is not on and the defrost thermostat is closed the control accumulates compressor run times at 30, 60 or 90 minute field adjustable intervals. If the defrost thermostat remains closed when the accumulated compressor run time ends, the defrost relay is energized and defrost begins.

Defrost Control Components

1- Defrost Control Timing Pins

Each timing pin selection provides a different accumulated compressor run period during one thermostat run cycle. This time period must occur before a defrost cycle is initiated. The defrost interval can be adjusted to 30, 60 or 90 minutes. See figure 8. The defrost period is a maximum of 14 minutes and cannot be adjusted. If no timing is selected, the control defaults to 90 minutes.

A TEST option is provided for troubleshooting. When the jumper is placed across the TEST pins, the timing of all functions is reduced by a factor of 128. For example, a 30 minute interval during TEST is 14 seconds and the 14-minute defrost is reduced to 6.5 seconds.

The TEST mode may be started at anytime. If the jumper is in the TEST position at power-up or for longer than five minutes, the control will ignore the TEST selection and will default to a 90 minute interval.

2- Time Delay

The timed-off delay is five minutes long. The delay feature is provided to help protect the compressor in case of an interruption in power to the unit or when a pressure switch resets.

3- Pressure Switch Safety Circuits

The defrost control incorporates a pressure switch safety circuit that allows the application of an additional pressure switch; high pressure switch (S4) is factory-wired to this circuit. See figure 8. PS1 and PS2 terminals are wired in series with a jumper internal to the control board.

HPXA15-1 units with defrost board date coded after 9936-8: During one demand cycle, the defrost control will lock out the unit on the third instance that the unit goes off on any auto-reset pressure switch. The diagnostic LEDs will display a pattern for a locked out pressure switch on the third open pressure switch occurrence. See table 3. This board contains a pressure switch counter and will reset every thermostat demand. The unit will remain locked out until Y1 demand is removed (making and breaking thermostat WILL reset board).

HPXA15-1 units with defrost board date coded before 9936-8: This board will lockout the unit after the third instance the unit goes off on any auto-reset pressure switch, regardless of the number of thermostat demand. Lockout can occur during one or multiple demands. This board contains a pressure switch counter and WILL NOT reset every thermostat demand. To reset the board 24 volt power must be broken to terminal “R” on the defrost control and then remade.

NOTE- If manual reset high pressure switch is used, unit will not experience 3 pressure trips during one demand cycle and the board will not lockout.

The PS2 safety circuit terminals are connected in series with the compressor contactor. An optional switch may be field-installed by connecting it in series with the other switches. See figure 8.

4- Diagnostic LEDs

The defrost board uses two LEDs for diagnostics. The LEDs flash a specific sequence according to the condition.

TABLE 3

DEFROST CONTROL BOARD DIAGNOSTIC LED		
MODE	LED 1	LED 2
Normal Operation/ Power to board	Flash together with LED 2	Flash together with LED 1
Time Delay To Protect Compressor	Alternating Flashes with LED 2	Alternating Flashes with LED 1
Pressure Switch Open	Off	On
Pressure Switch Lockout	On	Off
Board Malfunction	On	On

5- Ambient Thermistor & Service Light Connection

The defrost control board provides terminal connections for the ambient thermistor and service light. These features provide a service light thermostat which activates the room thermostat service light during periods of inefficient operation. The thermistor compensates for changes in ambient temperature which might cause thermostat droop.

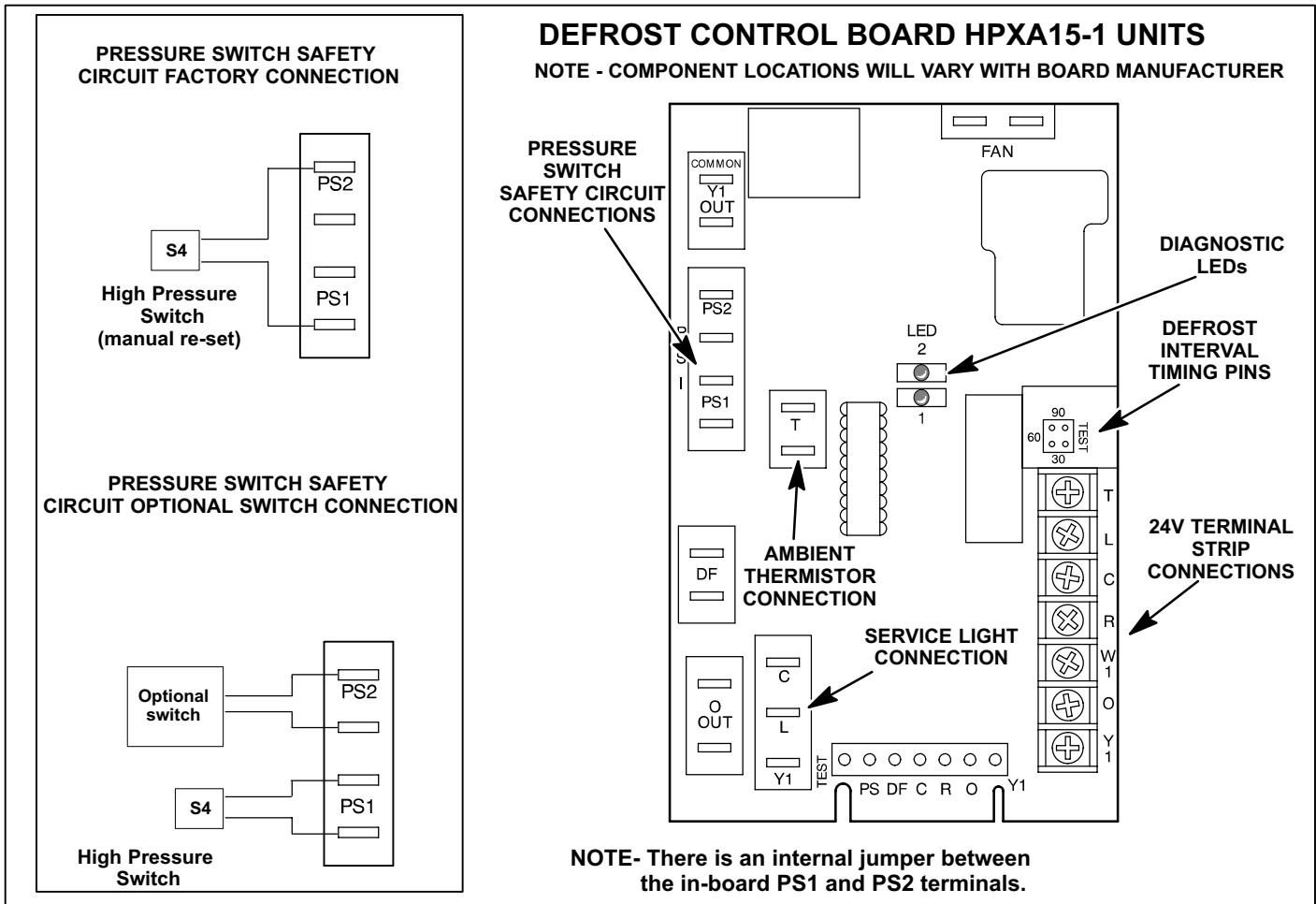

FIGURE 8

M-Time / Temperature Defrost System HPXA15-2 & -3 & HPXB15

The defrost system includes two components:

- a defrost thermostat
- a defrost control

Defrost Thermostat

The defrost thermostat is located on the liquid line between the check/expansion valve and the distributor. When the defrost thermostat senses 42°F (5.5°C) or cooler, its contacts close and send a signal to the defrost control board to start the defrost timing. It also terminates defrost when the liquid line warms up to 70°F (21°C).

Defrost Control

The defrost control board includes the combined functions of a time/temperature defrost control, defrost relay, time delay, diagnostic LEDs, and a terminal strip for field wiring connections. See figure 9.

The control provides automatic switching from normal heating operation to defrost mode and back. During compressor cycle (call for defrost), the control accumulates compressor run times at 30, 60, or 90 minute field adjustable intervals. If the defrost thermostat is closed when the selected compressor run time interval ends, the defrost relay is energized and defrost begins.

Defrost Control Timing Pins

Each timing pin selection provides a different accumulated compressor run time period during one thermostat run cycle. This time period must occur before a defrost cycle is initiated. The defrost interval can be adjusted to 30 (T1), 60 (T2), or 90 (T3) minutes. See figure 9. The defrost timing jumper is factory-installed to provide a 90-minute defrost interval. If the timing selector jumper is not in place, the control defaults to a 90-minute defrost interval. The maximum defrost period is 14 minutes and cannot be adjusted.

A TEST option is provided for troubleshooting. **The TEST mode may be started any time the unit is in the heating mode and the defrost thermostat is closed or jumpered.** If the jumper is in the TEST position at power-up, the control will ignore the test pins. When the jumper is placed across the TEST pins for two seconds, the control will enter the defrost mode. If the jumper is removed before an additional 5-second period has elapsed (7 seconds total), the unit will remain in defrost mode until the defrost thermostat opens or 14 minutes have passed. If the jumper is not removed until after the additional 5-second period has elapsed, the defrost will terminate and the test option will not function again until the jumper is removed and re-applied.

Time Delay

The timed-off delay is five minutes long. The delay helps protect the compressor from short-cycling in case the power to the unit is interrupted or a pressure switch opens. The delay is bypassed by placing the timer select jumper across the TEST pins for 0.5 seconds.

Compressor Delay HPXB15 Only

The defrost board has a built in function to reduce occasional noise that may occur while the unit is cycling in and out of defrost mode. The compressor will cycle off for 30 seconds going in and out of defrost mode.

NOTE - The 30 second off cycle is not functional when jumpering the TEST pins.

Pressure Switch Circuits

The defrost control includes two pressure switch circuits. The high pressure switch (S4) is factory-connected to the board's HI PS terminals. The board also includes LO PS terminals to accommodate the addition of a field-provided low pressure or loss of charge pressure switch. See figure 9. This feature is available on all units.

During a single demand cycle, the defrost control will lock out the unit after the third time on HPXA15-2 and -3 units and after the fifth time on HPXB15 units that the circuit is interrupted by any pressure switch that is wired to the control board. In addition, the diagnostic LEDs will indicate a locked out pressure switch after the third (HPXA15-2, -3) or fifth (HPXB15) occurrence of an open pressure switch. See table 4. The unit will remain locked out until power is broken then remade to the control or until the jumper is applied to the TEST pins for 0.5 seconds.

NOTE - The defrost control board ignores input from the low pressure switch terminals during the TEST mode, during the defrost cycle, during the 90-second start-up period, and for the first 90 seconds each time the reversing valve switches heat/cool modes. If the TEST pins are jumpered and the 5-minute delay is being bypassed, the LO PS terminal signal is not ignored during the 90-second start-up period.

Ambient Thermistor & Service Light Connection

The defrost control board provides terminal connections for the ambient thermistor and a service light. The thermistor compensates for changes in ambient temperature which might cause thermostat droop. The service light thermostat provides a signal which activates the room thermostat service light during periods of inefficient operation.

Diagnostic LEDs

The defrost board uses two LEDs for diagnostics. The LEDs flash a specific sequence according to the diagnosis.

TABLE 4

DEFROST CONTROL BOARD DIAGNOSTIC LED		
MODE	LED 1	LED 2
Normal operation / power to board	Synchronized Flash with LED 2	Synchronized Flash with LED 1
Board failure or no power	Off	Off
Board failure	On	On
High pressure switch open	Flash	On
Low pressure switch open	On	Flash
Pressure switch lockout	On	Off
Anti-short-cycle / 5-minute delay	Alternating Flash with LED 2	Alternating Flash with LED 1

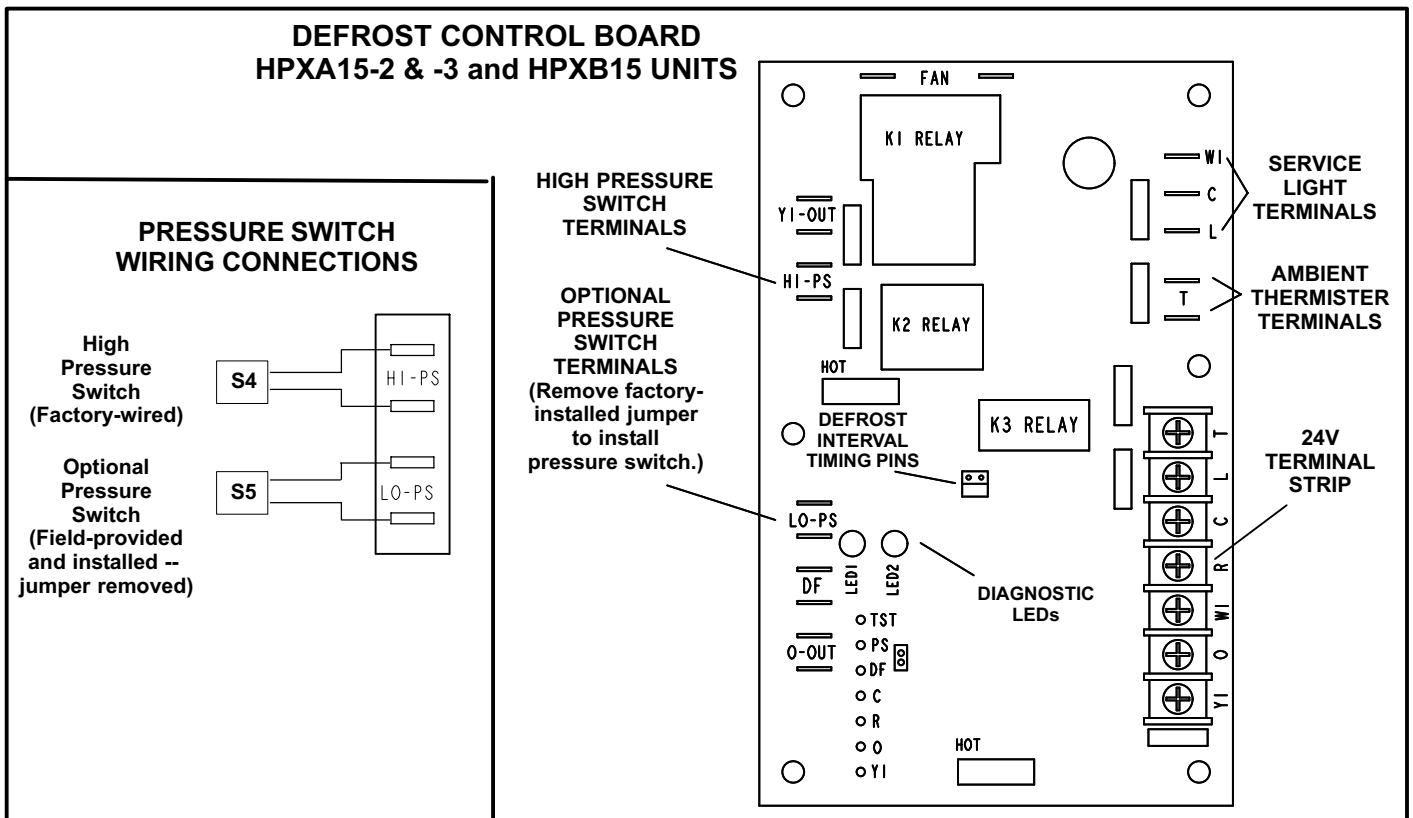

FIGURE 9

N-Drier

A filter drier designed for all units are factory installed in the liquid line. The filter drier is designed to remove moisture and foreign matter which can lead to compressor failure.

Moisture and / or Acid Check

Because POE oils absorb moisture, the dryness of the system must be verified any time the refrigerant system is exposed to open air. A compressor oil sample must be taken to determine if excessive moisture has been introduced to the oil. Table 6 lists kits available from Lennox to check POE oils.

If oil sample taken from a system that has been exposed to open air does not test in the dry color range, the filter drier **MUST** be replaced.

⚠ IMPORTANT

Replacement drier MUST be approved for R410A refrigerant and POE application.

Foreign Matter Check

It is recommended that a liquid line drier be replaced when the pressure drop across the filter drier is greater than 3 psig.

III-REFRIGERANT SYSTEM

Field refrigerant piping consists of liquid and vapor lines from the outdoor unit (sweat connections). Use Lennox L15 series line sets as shown in table 5.

Separate liquid and suction service ports are provided at the service valves for connection of gauge manifold during charging procedure. Figure 10 shows unit refrigerant flow and gauge manifold connections.

TABLE 5

Model	Valve Field Size Connections		Recommended Line Set		
	Liquid Line	Vapor Line	Liquid Line	Vapor Line	L15 Line Sets
-024 -030 -036	3/8 in. 10 mm	3/4 in. 19 mm	3/8 in. 10 mm	3/4 in. 19 mm	L15-41 15 ft. - 50 ft. 4.6 m - 15 m
-042 -048	3/8 in. 10 mm	7/8 in. 22 mm	3/8 in. 10 mm	7/8 in. 22 mm	L15-65 15 ft. - 50 ft. 4.6 m - 15 m
-060	3/8 in. 10 mm	1-1/8 in. 29 mm	3/8 in. 10 mm	1-1/8 in. 29 mm	Field Fabricated

TABLE 6

KIT	CONTENTS	TUBE SHELF LIFE
10N46 - Refrigerant Analysis	Checkmate-RT700	
10N45 - Acid Test Tubes	Checkmate-RT750A (three pack)	2 - 3 years @ room temperature. 3+ years refrigerated
10N44 - Moisture Test Tubes	Checkmate - RT751 Tubes (three pack)	6 - 12 months @ room temperature. 2 years refrigerated
74N40 - Easy Oil Test Tubes	Checkmate - RT752C Tubes (three pack)	2 - 3 years @ room temperature. 3+ years refrigerated
74N39 - Acid Test Kit	Sporlan One Shot - TA-1	

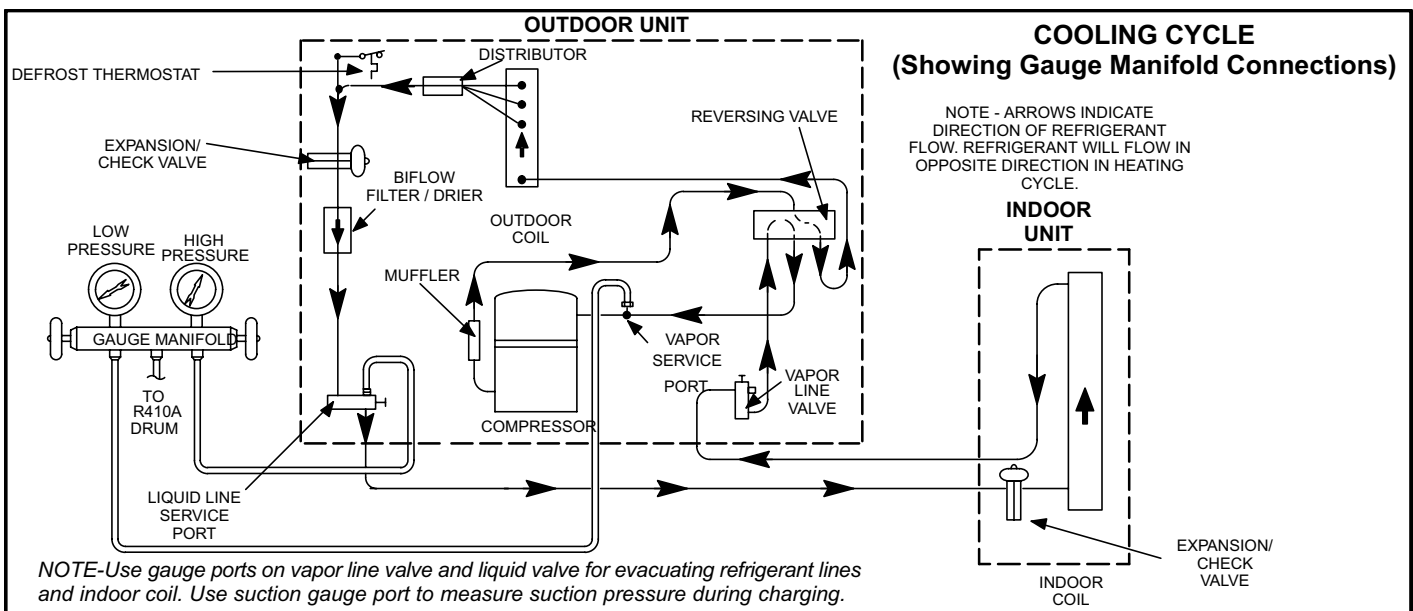

FIGURE 10

A-Service Valves

The liquid line and suction line service valves and gauge ports are accessible by removing the compressor access cover. See figures 11 and 12. The service ports are used for leak testing, evacuating, charging and checking charge. Service valves have a factory-installed schrader valve. A service port cap is supplied to protect the schrader valve from contamination and assure a leak free seal. Valves are not rebuildable. If a valve has failed it must be replaced. The pressure tap fitting has a LIGHT MAROON tag to remind service technicians that the unit contains R410A. Table 7 shows requirements.

TABLE 7

Part	Recommended Torque	
Service valve cap	8 ft.- lb.	11 NM
Sheet metal screws	16 in.- lb.	2 NM
Machine screws #10	28 in.- lb.	3 NM
Compressor bolts	90 in.- lb.	10 NM
Gauge port seal cap	8 ft.- lb.	11 NM

To Access Schrader Port:

- 1 - Remove service port cap with an adjustable wrench.
- 2 - Connect gauge to the service port.
- 3 - When testing is complete, replace service port cap. Tighten finger tight, then an additional 1/6 turn.

To Open Service Valve:

- 1 - Remove the stem cap with an adjustable wrench.
- 2 - Use a service wrench with a hex-head extension to back the stem out counterclockwise as far as it will go.
NOTE - Use a 3/16" hex head extension for liquid line sizes or a 5/16" extension for vapor line sizes.
- 3 - Replace the stem cap. Tighten finger tight, then tighten an additional 1/6 turn.

To Close Service Valve:

- 1 - Remove the stem cap with an adjustable wrench.
- 2 - Use a service wrench with a hex-head extension to turn the stem clockwise to seat the valve. Tighten the stem firmly.
NOTE - Use a 3/16" hex head extension for liquid line sizes or a 5/16" extension for vapor line sizes.
- 3 - Replace the stem cap. Tighten finger tight, then tighten an additional 1/6 turn.

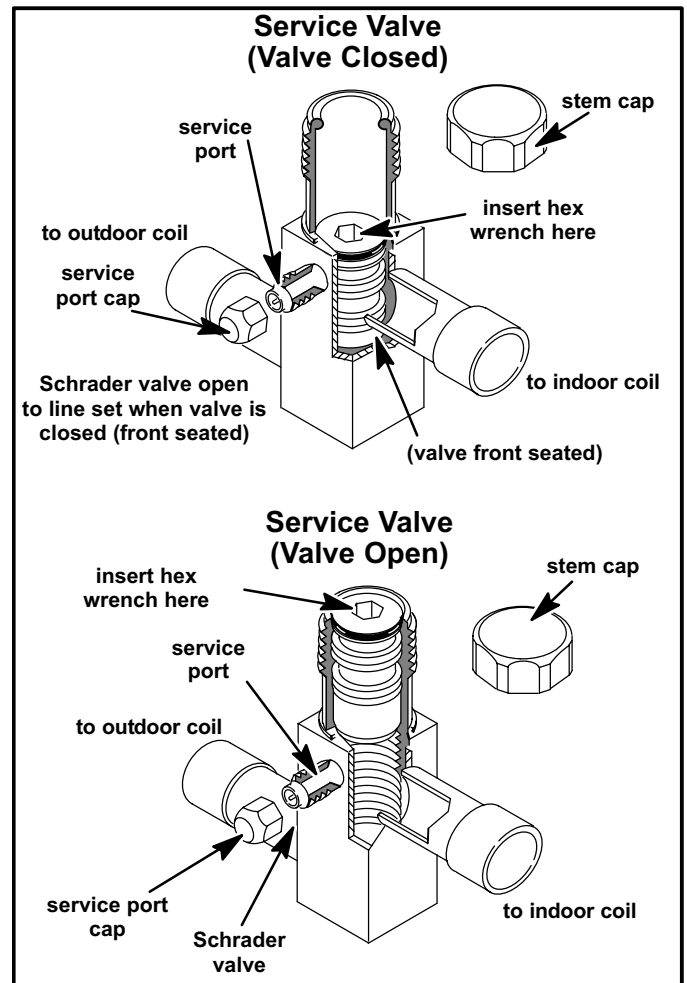

FIGURE 11

Vapor Line Ball Valve (4 and 5 ton only)

Vapor line service valves function the same way as the other valves, the difference is in the construction. These valves are not rebuildable. If a valve has failed, you must replace it. A ball valve is illustrated in figure 12.

The ball valve is equipped with a service port with a factory-installed Schrader valve. A service port cap protects the Schrader valve from contamination and assures a leak-free seal.

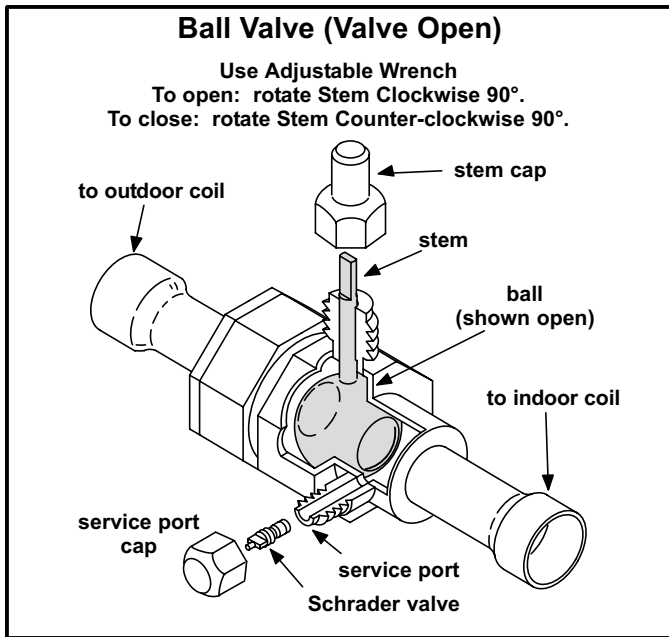

FIGURE 12

IV-CHARGING

Units are factory charged with the amount of R410A refrigerant indicated on the unit rating plate. This charge is based on a matching indoor coil and outdoor coil with 15 ft. (4.5m) line set. For varying lengths of line set, refer to table 8 for refrigerant charge adjustment.

TABLE 8

Liquid Line Set Diameter	Ozs. per 5 ft. (grams per 1.5m) adjust from 15 ft. (4.5m) line set*
3/8 in. (10mm)	3 ounces per 5 feet (85g per 1.5m)

*If line length is greater than 15 ft. (4.5 m), add this amount. If line length is less than 15 ft. (4.5m), subtract this amount.

A-Leak Testing

After the line set has been connected to the indoor and outdoor units, check the line set connections and indoor unit for leaks.

⚠ WARNING

Refrigerant can be harmful if it is inhaled. Refrigerant must be used and recovered responsibly.

Failure to follow this warning may result in personal injury or death.

⚠ WARNING



Danger of explosion: Can cause equipment damage, injury or death. Never use oxygen to pressurize a refrigeration or air conditioning system. Oxygen will explode on contact with oil and could cause personal injury.

⚠ WARNING

Danger of explosion: Can cause equipment damage, injury or death. When using a high pressure gas such as dry nitrogen to pressurize a refrigeration or air conditioning system, use a regulator that can control the pressure down to 1 or 2 psig (6.9 to 13.8 kPa).

Using an Electronic Leak Detector or Halide

- 1 - Connect a cylinder of R410A to the center port of the manifold gauge set.
- 2 - With both manifold valves closed, open the valve on the R410A cylinder (vapor only).
- 3 - Open the high pressure side of the manifold to allow the R410A into the line set and indoor unit. Weigh in a trace amount of R410A [A trace amount is a maximum of 2 ounces (57 g) or 3 pounds (31 kPa) pressure.] Close the valve on the R410A cylinder and the valve on the high pressure side of the manifold gauge set. Disconnect the R410A cylinder.
- 4 - Connect a cylinder of nitrogen with a pressure regulating valve to the center port of the manifold gauge set.
- 5 - Connect the manifold gauge set high pressure hose to the vapor valve service port. (Normally, the high pressure hose is connected to the liquid line port; however, connecting it to the vapor port better protects the manifold gauge set from high pressure damage.)
- 6 - Adjust the nitrogen pressure to 150 psig (1034 kPa). Open the valve on the high side of the manifold gauge set which will pressurize line set and indoor unit.
- 7 - After a few minutes, open a refrigerant port to ensure the refrigerant you added is adequate to be detected. (Amounts of refrigerant will vary with line lengths.) Check all joints for leaks. Purge nitrogen and R410 mixture. Correct any leaks and recheck.

B-Evacuating the System

Evacuating the system of noncondensables is critical for proper operation of the unit. Noncondensables are defined as any gas that will not condense under temperatures and pressures present during operation of an air conditioning system. Noncondensables and water vapor combine with refrigerant to produce substances that corrode copper piping and compressor parts.

NOTE - This evacuation process is adequate for a new installation with clean and dry lines. If excessive moisture is present, the evacuation process may be required more than once.

⚠ IMPORTANT

Use a thermocouple or thermistor electronic vacuum gauge that is calibrated in microns. Use an instrument that reads from 50 microns to at least 10,000 microns.

- 1 - Connect manifold gauge set to the service valve ports :
 - low pressure gauge to vapor line service valve
 - high pressure gauge to liquid line service valve

- 2 - Connect micron gauge.
- 3 - Connect the vacuum pump (with vacuum gauge) to the center port of the manifold gauge set.
- 4 - Open both manifold valves and start the vacuum pump.
- 5 - Evacuate the line set and indoor unit to an **absolute pressure** of 23,000 microns (29.01 inches of mercury). During the early stages of evacuation, it is desirable to close the manifold gauge valve at least once to determine if there is a rapid rise in **absolute pressure**. A rapid rise in pressure indicates a relatively large leak. If this occurs, repeat the leak testing procedure.
*NOTE - The term **absolute pressure** means the total actual pressure within a given volume or system, above the absolute zero of pressure. Absolute pressure in a vacuum is equal to atmospheric pressure minus vacuum pressure.*
- 6 - When the absolute pressure reaches 23,000 microns (29.01 inches of mercury), close the manifold gauge valves, turn off the vacuum pump and disconnect the manifold gauge center port hose from vacuum pump. Attach the manifold center port hose to a nitrogen cylinder with pressure regulator set to 150 psig (1034 kPa) and purge the hose. Open the manifold gauge valves to break the vacuum in the line set and indoor unit. Close the manifold gauge valves.

CAUTION

Danger of Equipment Damage. Avoid deep vacuum operation. Do not use compressors to evacuate a system. Extremely low vacuums can cause internal arcing and compressor failure. Damage caused by deep vacuum operation will void warranty.

- 7 - Shut off the nitrogen cylinder and remove the manifold gauge hose from the cylinder. Open the manifold gauge valves to release the nitrogen from the line set and indoor unit.
- 8 - Reconnect the manifold gauge to the vacuum pump, turn the pump on, and continue to evacuate the line set and indoor unit until the absolute pressure does not rise above 500 microns (29.9 inches of mercury) within a 20-minute period after shutting off the vacuum pump and closing the manifold gauge valves.
- 9 - When the absolute pressure requirement above has been met, disconnect the manifold hose from the vacuum pump and connect it to an upright cylinder of R410A refrigerant. Open the manifold gauge valves to break the vacuum from 1 to 2 psig positive pressure in the line set and indoor unit. Close manifold gauge valves and shut off the R410A cylinder and remove the manifold gauge set.

C-Charging

This system is charged with R410A refrigerant which operates at much higher pressures than R22. The check/expansion valve provided with the unit is approved for use with R410A. Do not replace it with a valve designed for use with R22. This unit is NOT approved for use with coils which include metering orifices or capillary tubes.

Processing Procedure

The unit is factory-charged with the amount of R410A refrigerant indicated on the unit rating plate. This charge is based on a matching indoor coil and outdoor coil with a 15 foot line set. For varying lengths of line set, refer to table 8 for refrigerant charge adjustment.

IMPORTANT

Mineral oils are not compatible with R410A. If oil must be added, it must be a polyol ester oil.

The compressor is charged with sufficient polyol ester oil for line set lengths up to 50 ft.

It is desirable to charge the system in the cooling cycle if weather conditions permit. However, if the unit must be charged in the heating season, one of the following procedures must be followed to ensure proper system charge.

Weighing in the Charge Fixed Orifice or TXV Systems – Outdoor Temp < 65° F (18° C)

If the system is void of refrigerant, or if the outdoor ambient temperature is cool, the refrigerant charge should be weighed into the unit. Do this after any leaks have been repaired.

- 1 - Recover the refrigerant from the unit.
- 2 - Conduct a leak check, then evacuate as previously outlined.
- 3 - Weigh in the unit nameplate charge.

If weighing facilities are not available or if you are charging the unit during warm weather, follow one of the other procedures outlined below.

**Charging Using the Subcooling Method
Fixed Orifice Systems – Outdoor Temp.
≥ 65° F (18° C)**

If you charge a fixed orifice system when the outdoor ambient is 65° F (18° C) or above, use the subcooling method to charge the unit.

- 1 - With the manifold gauge hose still on the liquid service port and the unit operating stably, use a digital thermometer to record the liquid line temperature.
- 2 - At the same time, record the liquid line pressure reading.
- 3 - Use a temperature/pressure chart for R410A to determine the saturation temperature for the liquid line pressure reading.
- 4 - Subtract the liquid line temperature from the saturation temperature (according to the chart) to determine subcooling. **(Saturation temperature - Liquid line temperature = Subcooling)**
- 5 - Compare the subcooling value with those in table 9. If subcooling is greater than shown, recover some refrigerant. If subcooling is less than shown, add some refrigerant.

**TABLE 9
Subcooling Values for Charging**

Model Number	Subcooling Values Conversion Temp. - Liquid Line Temp. °F (°C)
HPXA/B15-24	5 ± 1 (2.8 ± .5)
HPXA/B15-30	8 ± 1 (7.4 ± .5)
HPXA/B15-36	5.5 ± 1 (3 ± .5)
HPXA/B15-42	4.5 ± 1 (2.5 ± .5)
HPXA/B15-48	2.5 ± 1 (1.4 ± .5)
HPXA/B15-60	6 ± 1 (3.3 ± .5)

**Approach and Normal Operating Pressures
TXV Systems – Outdoor Temp. ≥ 65° F (18° C)**

The following procedure is intended as a general guide and is for use on expansion valve systems only. For best results, indoor temperature should be 70°F (21°C) to 80°F (26°C). Monitor system pressures while charging.

- 1 - Record outdoor ambient temperature using a digital thermometer.
- 2 - Attach high pressure gauge set and operate unit for several minutes to allow system pressures to stabilize.
- 3 - Compare stabilized pressures with those provided in table 11, "Normal Operating Pressures." Minor variations in these pressures may be expected due to differences in installations. Significant differences could mean that the system is not properly charged or that a problem exists with some component in the system. Pressures higher than those listed indicate that the system is overcharged. Pressures lower than those listed indicate that the system is undercharged. Verify adjusted charge using the approach method.
- 4 - Outdoor temperature should be 65°F (18°C) or above. Use the same digital thermometer used to check outdoor ambient temperature to check liquid line temperature. Verify the unit charge using the approach method. The difference between the ambient and liquid temperatures should match values given in table 3. Refrigerant must be added to lower approach temperature and removed to increase approach temperature. Loss of charge results in low capacity and efficiency.
- 5 - If the values don't agree with the those in table 10, add refrigerant to lower the approach temperature or recover refrigerant from the system to increase the approach temperature.

**TABLE 10
Approach Values for Charging**

Model Number	Approach Temperature Liquid Line Temp. - Outdoor Ambient °F (°C)
HPXA/B15-24	13 ± 1 (7.2 ± .5)
HPXA/B15-30	7 ± 1 (3.9 ± .5)
HPXA/B15-36	11 ± 1 (6.1 ± .5)
HPXA/B15-42	12.5 ± 1 (6.9 ± .5)
HPXA/B15-48	10 ± 1 (5.6 ± .5)
HPXA/B15-60	11.5 ± 1 (6.5 ± .5)

**TABLE 11
NORMAL OPERATING PRESSURES
(Liquid ±10 and Vapor ±5 psig)**

COOLING OPERATION												
OUTDOOR COIL ENTERING AIR TEMP F° (C°)	HPXA/B15-24		HPXA/B15-30		HPXA/B15-36		HPXA/B15-42		HPXA/B15-48		HPXA/B15-60	
	Liquid	Vapor	Liquid	Vapor	Liquid	Vapor	Liquid	Vapor	Liquid	Vapor	Liquid	Vapor
65 (18.3)	252	131	233	141	216	136	240	133	228	137	231	124
75 (23.9)	291	133	272	142	276	138	281	135	265	139	269	126
85 (29.4)	337	135	314	143	298	139	325	137	304	141	315	127
95 (35.0)	371	140	360	146	359	141	372	138	348	142	370	133
105 (40.6)	421	142	413	148	400	143	428	142	405	145	415	136
HEATING OPERATION												
OUTDOOR COIL ENTERING AIR TEMP F° (C°)	HPXA/B15-24		HPXA/B15-30		HPXA/B15-36		HPXA/B15-42		HPXA/B15-48		HPXA/B15-60	
	Liquid	Vapor	Liquid	Vapor	Liquid	Vapor	Liquid	Vapor	Liquid	Vapor	Liquid	Vapor
20 (-6.6)	288	60	270	67	234	62	340	65	313	60	245	55
30 (-1.1)	306	75	297	84	257	80	350	72	330	73	287	66
40 (4.4)	325	90	325	100	318	93	353	83	346	87	332	82
50 (10.0)	344	105	353	117	322	103	358	101	366	101	347	99

TABLE 12
R410A Temperature/Pressure Chart

Temperature °F	Pressure Psig	Temperature °F	Pressure Psig	Temperature °F	Pressure Psig	Temperature °F	Pressure Psig
32	100.8	63	178.5	94	290.8	125	445.9
33	102.9	64	181.6	95	295.1	126	451.8
34	105.0	65	184.3	96	299.4	127	457.6
35	107.1	66	187.7	97	303.8	128	463.5
36	109.2	67	190.9	98	308.2	129	469.5
37	111.4	68	194.1	99	312.7	130	475.6
38	113.6	69	197.3	100	317.2	131	481.6
39	115.8	70	200.6	101	321.8	132	487.8
40	118.0	71	203.9	102	326.4	133	494.0
41	120.3	72	207.2	103	331.0	134	500.2
42	122.6	73	210.6	104	335.7	135	506.5
43	125.0	74	214.0	105	340.5	136	512.9
44	127.3	75	217.4	106	345.3	137	519.3
45	129.7	76	220.9	107	350.1	138	525.8
46	132.2	77	224.4	108	355.0	139	532.4
47	134.6	78	228.0	109	360.0	140	539.0
48	137.1	79	231.6	110	365.0	141	545.6
49	139.6	80	235.3	111	370.0	142	552.3
50	142.2	81	239.0	112	375.1	143	559.1
51	144.8	82	242.7	113	380.2	144	565.9
52	147.4	83	246.5	114	385.4	145	572.8
53	150.1	84	250.3	115	390.7	146	579.8
54	152.8	85	254.1	116	396.0	147	586.8
55	155.5	86	258.0	117	401.3	148	593.8
56	158.2	87	262.0	118	406.7	149	601.0
57	161.0	88	266.0	119	412.2	150	608.1
58	163.9	89	270.0	120	417.7	151	615.4
59	166.7	90	274.1	121	423.2	152	622.7
60	169.6	91	278.2	122	428.8	153	630.1
61	172.6	92	282.3	123	434.5	154	637.5
62	195.5	93	286.5	124	440.2	155	645.0

V-SERVICE AND RECOVERY

⚠ WARNING

Polyol ester (POE) oils used with R410A refrigerant absorb moisture very quickly. It is very important that the refrigerant system be kept closed as much as possible. **DO NOT** remove line set caps or service valve stub caps until you are ready to make connections.

⚠ IMPORTANT

Use recovery machine rated for R410 refrigerant.

If the system must be opened for any kind of service, such as compressor or filter drier replacement, you must take extra precautions to prevent moisture from entering the system. The following steps will help to minimize the amount of moisture that enters the system during recovery of R410A.

- 1 - Use a regulator-equipped nitrogen cylinder to break the system vacuum. Do not exceed 5 psi. The dry nitrogen will fill the system, and will help purge any moisture.
- 2 - Remove the faulty component and quickly seal the system (using tape or some other means) to prevent additional moisture from entering the system.
- 3 - Do not remove the tape until you are ready to install new component. Quickly install the replacement component.
- 4 - Evacuate the system to remove any moisture and other non-condensables.

The HPXA15 and HPXB15 systems MUST be checked for moisture any time the sealed systems are opened.

Any moisture not absorbed by the polyol ester oil can be removed by triple evacuation. Moisture that has been absorbed by the compressor oil can be removed by replacing the filter drier.

⚠ IMPORTANT

Evacuation of system only will not remove moisture from oil. Filter drier must be replaced to eliminate moisture from POE oil.

VI-MAINTENANCE

⚠ WARNING



Electric shock hazard. Can cause injury or death. Before attempting to perform any service or maintenance, turn the electrical power to unit OFF at disconnect switch(es). Unit may have multiple power supplies.

Maintenance and service must be performed by a qualified installer or service agency. At the beginning of each cooling season, the system should be checked as follows:

- 1 - Clean and inspect the outdoor coil. The coil may be flushed with a water hose. Ensure the power is turned off before you clean the coil.
- 2 - Condenser fan motor is prelubricated and sealed. No further lubrication is needed.
- 3 - Visually inspect connecting lines and coils for evidence of oil leaks.
- 4 - Check wiring for loose connections.
- 5 - Check for correct voltage at unit (unit operating).
- 6 - Check amp-draw condenser fan motor.

NOTE - If owner complains of insufficient cooling, the unit should be gauged and refrigerant charge checked. Refer to section on refrigerant charging in this instruction.

Indoor Coil

- 1 - Clean coil, if necessary.
- 2 - Check connecting lines and coils for evidence of oil leaks.
- 3 - Check the condensate line and clean it if necessary.

Indoor Unit

- 1 - Clean or change filters.
- 2 - Adjust blower speed for cooling. Measure the pressure drop over the coil to determine the correct blower CFM. Refer to the unit information service manual for pressure drop tables and procedure.
- 3 - *Belt Drive Blowers* - Check belt for wear and proper tension.
- 4 - Check all wiring for loose connections
- 5 - Check for correct voltage at unit (blower operating).
- 6 - Check amp-draw on blower motor.

VII-DIAGRAM / OPERATING SEQUENCE

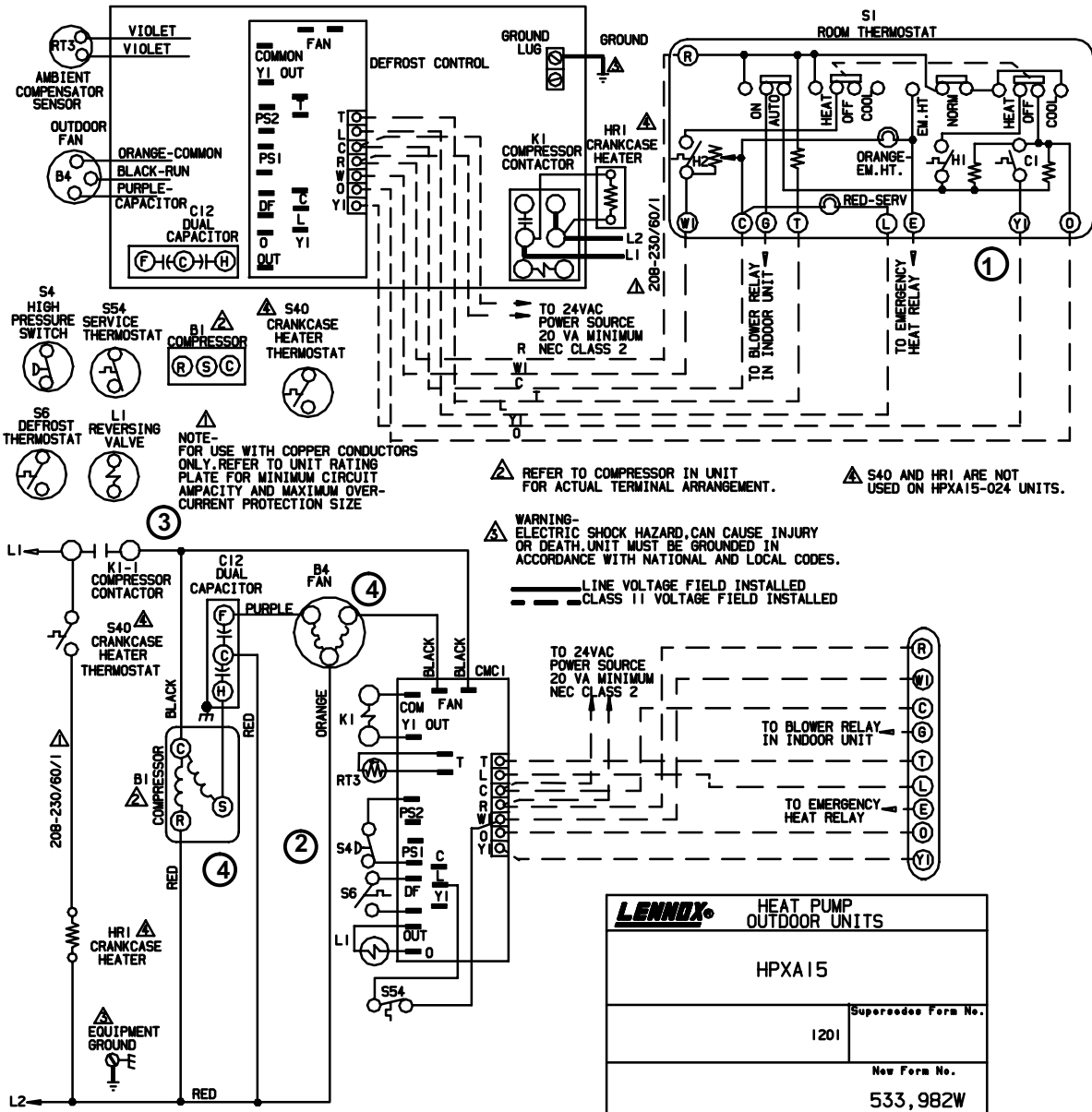

LENNOX HEAT PUMP OUTDOOR UNITS	
HPXA15	
Supersedes Form No.	
1201	
New Form No.	
533,982W	

©2001 Lennox Industries Inc. Little U.S.A.

COOLING

- Transformer from indoor unit supplies 24VAC power to the thermostat and outdoor unit controls.
- Internal wiring energizes terminal O by cooling mode selection, energizing the reversing valve. Cooling demand initiates at Y1 in the thermostat.
- 24VAC energizes N.C. high pressure limit S4 energizing compressor contactor K1.
- K1-1 N.O. closes energizing compressor B1 and outdoor fan motor B4. Compressor B1 and outdoor fan motor B4 begin immediate operation.

HEATING

- Internal wiring de-energizes terminal O by heating mode selection, de-energizing the reversing valve. Heating demand initiates at Y1.
- 24VAC energizes N.C. high pressure limit S4, energizing compressor contactor K1.
- K1-1 N.O. closes energizing compressor and outdoor fan motor
- Compressor B1 and outdoor fan motor B4 begin immediate operation.

DEFROST MODE

- During heating operation when outdoor coil temperature drops below 35°F (2°C) or 42°F (5.5°C) see defrost system description for specific unit dash number defrost switch (thermostat) S6 closes.
- Defrost control CMC1 begins timing. If defrost thermostat (S6) remains closed at the end of the 30, 60 or 90 minute period, defrost relay energizes and defrost begins.
- During defrost CMC1 energizes the reversing valve and W1 on the terminal strip (operating indoor unit on the first stage heat mode), while de-energizing outdoor fan motor B4.
- Defrost continues 14 ± 1 minutes or until thermostat switch (S6) opens. When defrost thermostat opens, defrost control timer loses power and resets.
- When CMC1 resets, the reversing valve and W1 on the terminal strip are de-energized, while the outdoor fan motor B4 is energized.
- After each thermostat demand, time delay locks out the circuit to compressor contactor coil and defrost control for 5 minutes ± 2 minutes. At the end of the timed period, the time delay allows the compressor contactor and defrost control to be energized upon demand as in step 1.

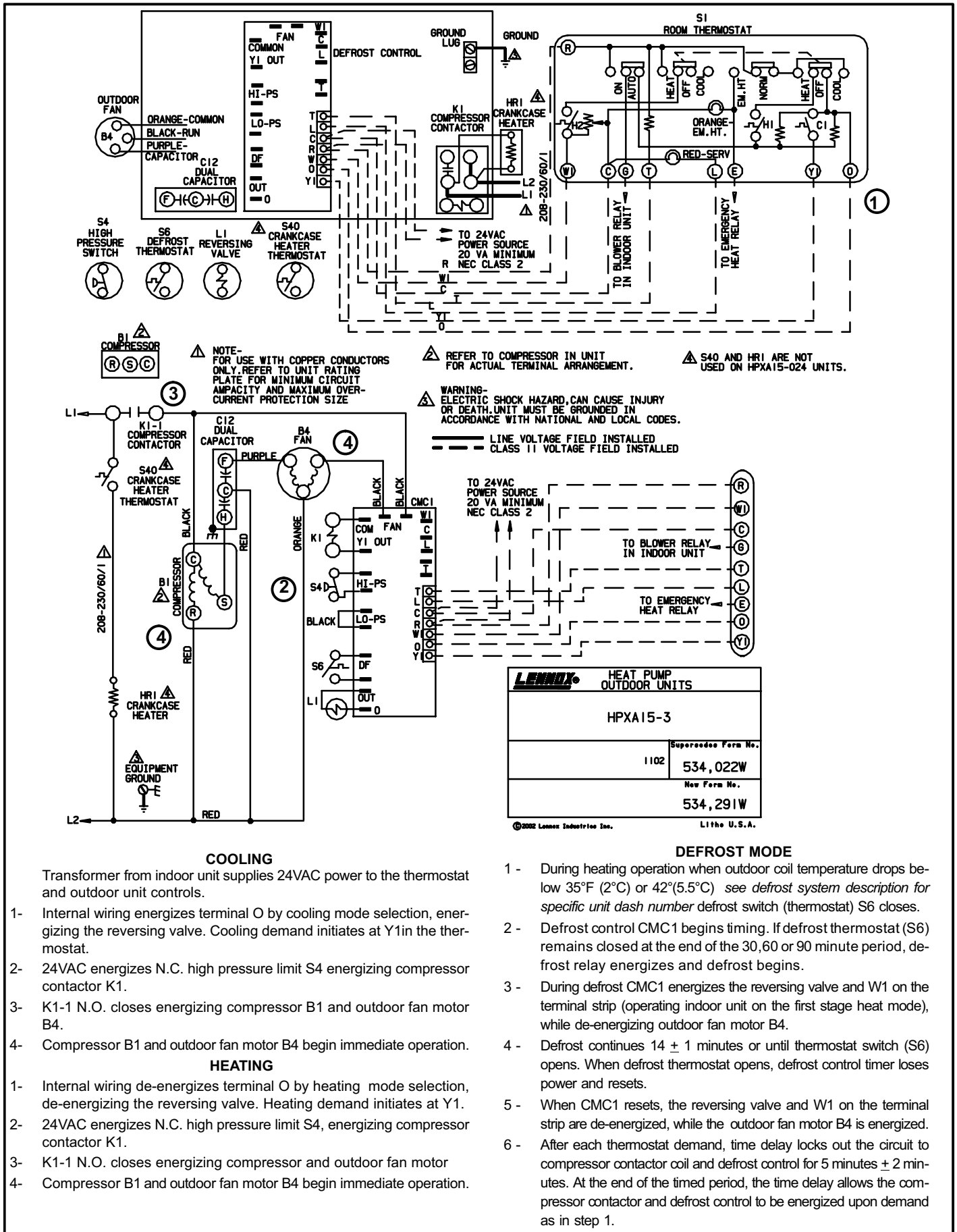

COOLING

Transformer from indoor unit supplies 24VAC power to the thermostat and outdoor unit controls.

- Internal wiring energizes terminal O by cooling mode selection, energizing the reversing valve. Cooling demand initiates at Y1 in the thermostat.
- 24VAC energizes N.C. high pressure limit S4 energizing compressor contactor K1.
- K1-1 N.O. closes energizing compressor B1 and outdoor fan motor B4.
- Compressor B1 and outdoor fan motor B4 begin immediate operation.

HEATING

- Internal wiring de-energizes terminal O by heating mode selection, de-energizing the reversing valve. Heating demand initiates at Y1.
- 24VAC energizes N.C. high pressure limit S4, energizing compressor contactor K1.
- K1-1 N.O. closes energizing compressor and outdoor fan motor
- Compressor B1 and outdoor fan motor B4 begin immediate operation.

DEFROST MODE

- During heating operation when outdoor coil temperature drops below 35°F (2°C) or 42°F (5.5°C) see defrost system description for specific unit dash number defrost switch (thermostat) S6 closes.
- Defrost control CMC1 begins timing. If defrost thermostat (S6) remains closed at the end of the 30, 60 or 90 minute period, defrost relay energizes and defrost begins.
- During defrost CMC1 energizes the reversing valve and W1 on the terminal strip (operating indoor unit on the first stage heat mode), while de-energizing outdoor fan motor B4.
- Defrost continues 14 ± 1 minutes or until thermostat switch (S6) opens. When defrost thermostat opens, defrost control timer loses power and resets.
- When CMC1 resets, the reversing valve and W1 on the terminal strip are de-energized, while the outdoor fan motor B4 is energized.
- After each thermostat demand, time delay locks out the circuit to compressor contactor coil and defrost control for 5 minutes ± 2 minutes. At the end of the timed period, the time delay allows the compressor contactor and defrost control to be energized upon demand as in step 1.

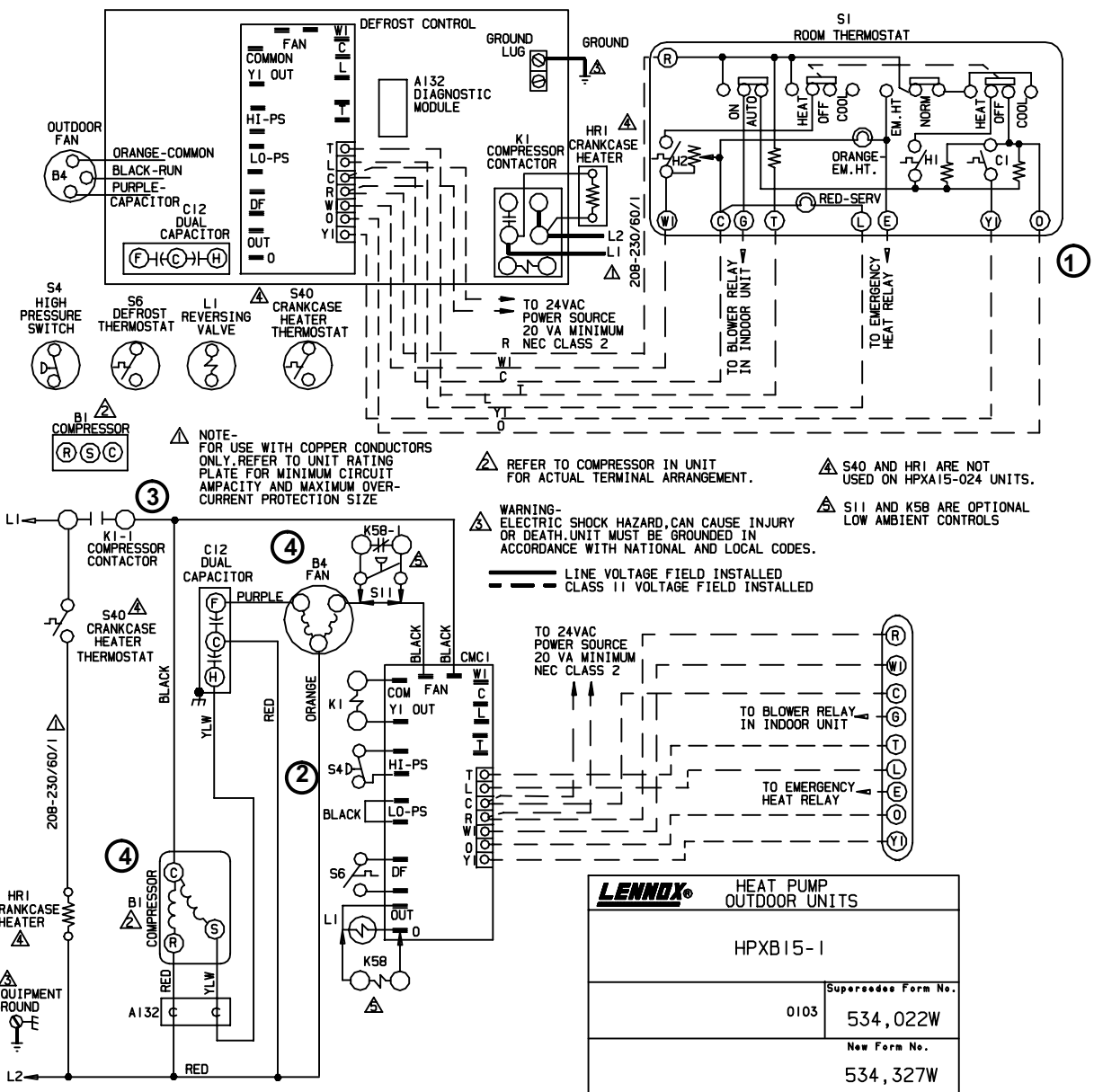

COOLING

Transformer from indoor unit supplies 24VAC power to the thermostat 1 - and outdoor unit controls.

- 1- Internal wiring energizes terminal O by cooling mode selection, energizing the reversing valve. Cooling demand initiates at Y1 in the thermostat. 2 -
- 2- 24VAC energizes N.C. high pressure limit S4 energizing compressor contactor K1. 2 -
- 3- K1-1 N.O. closes energizing compressor B1 and outdoor fan motor B4. 3 -
- 4- Compressor B1 and outdoor fan motor B4 begin immediate operation. 4 -

HEATING

- 1- Internal wiring de-energizes terminal O by heating mode selection, de-energizing the reversing valve. Heating demand initiates at Y1. 4 -
- 2- 24VAC energizes N.C. high pressure limit S4, energizing compressor contactor K1. 4 -
- 3- K1-1 N.O. closes energizing compressor and outdoor fan motor 5 -
- 4- Compressor B1 and outdoor fan motor B4 begin immediate operation. 6 -

DEFROST MODE

During heating operation when outdoor coil temperature drops below 35°F (2°C) or 42°F (5.5°C) see defrost system description for specific unit dash number defrost switch (thermostat) S6 closes.

Defrost control CMC1 begins timing. If defrost thermostat (S6) remains closed at the end of the 30, 60 or 90 minute period, defrost relay energizes and defrost begins.

During defrost CMC1 energizes the reversing valve and W1 on the terminal strip (operating indoor unit on the first stage heat mode), while de-energizing outdoor fan motor B4.

Defrost continues 14 ± 1 minutes or until thermostat switch (S6) opens. When defrost thermostat opens, defrost control timer loses power and resets.

When CMC1 resets, the reversing valve and W1 on the terminal strip are de-energized, while the outdoor fan motor B4 is energized.

After each thermostat demand, time delay locks out the circuit to compressor contactor coil and defrost control for 5 minutes ± 2 minutes. At the end of the timed period, the time delay allows the compressor contactor and defrost control to be energized upon demand as in step 1.

LENNOX® HEAT PUMP OUTDOOR UNITS	
HPXB15-1	
0103	Supersedes Form No. 534,022W
New Form No. 534,327W	

©2003 Lennox Industries Inc.

Litho U.S.A.